



RoHS Compliant

ERON®

No.E-231

Pull Down Free Jaw Vises

- Can be used when a bigger opening that cannot be obtained using an ordinary machine vise is needed.
- Any size of workpiece can be clamped to match the table, including planar, shaper, miller, and boring machine.
- Since the workpiece is clamped by pulling down, floating up is prevented in spite of the powerful clamping force.
- The main body uses Nabeya special ductile cast iron, and does not break.
- The keys are the high accuracy and ground finish.

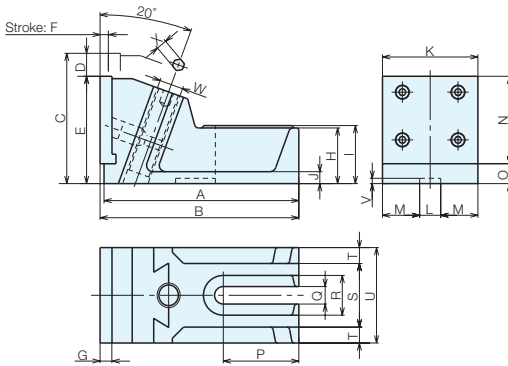

Standard Accessories PV-1



Standard Accessories PV-2 and PV-3

Accessories

	Standard Guide Block (2 pieces per set)	Serrated Jaw plate	T-slot Bolt	Hex Nut	Washer	Fixed Block	Hex Bolt	Large Angle Wrench (For Clamping and for Jaw Plates)
PV-0	-	2 pieces	-	-	M12: 2 pieces	-	M12X45 2 pieces	1 pieces of each
PV-1	-	2 pieces	M14: Compatible T-slot 14.18 4 pieces	M14: 4 pieces	M14: 4 pieces	-	-	1 pieces of each
PV-2	Compatible groove width 18 mm 1 set	2 pieces	M14: Compatible T-slot 14.18 6 pieces	M14: 6 pieces	M14: 6 pieces	2 pieces	-	1 pieces of each
PV-3	Compatible groove width 18 mm 1 set	2 pieces	M18: Compatible T-slot 18.22 6 pieces	M18: 6 pieces	M18: 6 pieces	2 pieces	-	1 pieces of each

Size Chart

No.	A	B	C	D	E	F	G	H	I	J	K	L	M	N	O	P	Q	R	S	T	U	V	W	X
PV-0	70	73	50	8	42	3	9	21	23	5	46	-	-	30	12	9	13.5	25	36	5	46	-	Tr18P2	6
PV-1	127	130	64	8	56	3	10	30	32	7	62	-	-	40	16	51	15	32	48	7	62	-	Tr22P4	8
PV-2	180	186	102	20	82	7	12	40	43	12	85	18	34.5	60	22	73	19	40	65	10	85	5	Tr28P4	10
PV-3	245	250	164	29	135	10.5	15	70	73	15	120	18	49	110	25	95	22	50	80	20	120	6	Tr30P6	14

Specifications

(2 pieces per set)

Order No.	No.	Jaw Width	Minimum Height	Maximum Height	Standard Guide Block Width	Set Weight (kg)
27331	PV-0	46	42	50	-	1.5
00536	PV-1	62	56	64	-	4.8
00537	PV-2	85	82	102	18	12.5
00538	PV-3	120	135	164	18	39.1

Usage Examples

